

SCIONON® LIMITED

SCIONON® Graft Crafter™

Full Modular Unit

Copyright
ACE HORTICULTURE
January 2012

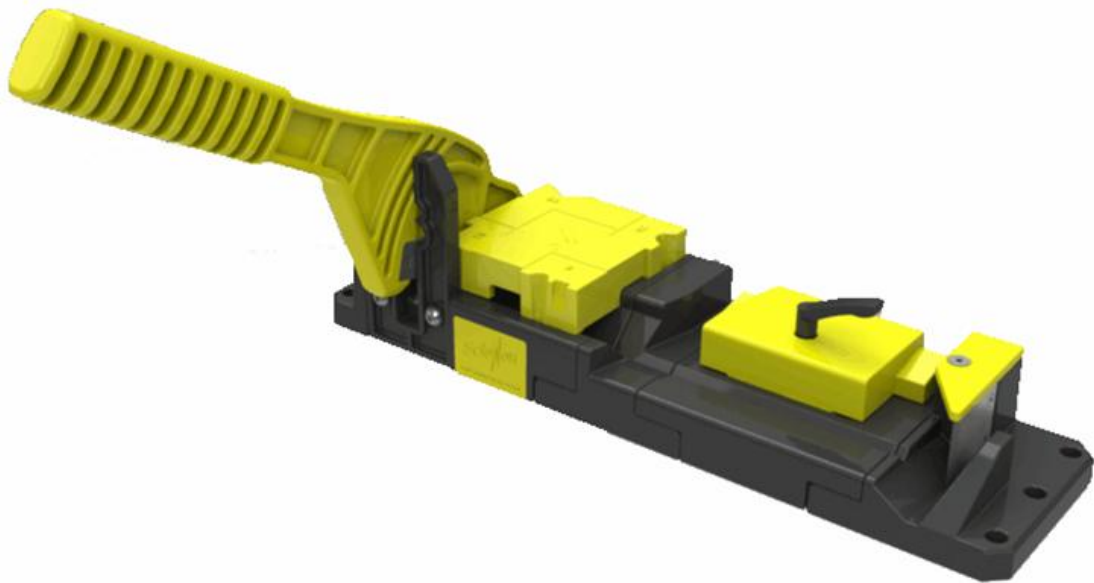

Assembly Operator's Manual for
SCIONON® Graft Crafter™ - SGC4
Full Modular Unit (FMU) - 2012

NEW ZEALAND DESIGNED AND MADE

Developers of Innovative Grafting Tools

1. CONTENTS

Page 2	1. Contents
Page 3	2. Parts check list - Model FMU, Product Code SGC4
Page 4	3. Full parts explode view - GBU3
Page 5	4A. Parts list Guillotine Base unit GBU3
Page 6	4B. Parts list Drop Saw Unit, TSU & FMU
Page 7	5. Assembly instructions - GBU3
Page 8	6. Introduction
	7. Getting started
	8. Assembly detail
Page 9	9. Safety first
	10. Preparation
	11. Practice cuts
Page 10	12. Cutting & shaping the scions
Page 11	13. Preparing rind grafts
	14. Preparing whip & tongue grafts
Page 12	15. Preparing wedge grafts
	16. Preparing 'V' cleft grafts
Page 13	17. Preparing chip buds
	18. Blade care & replacement
	19. General maintenance & storage
Page 14	20. Modular multi-tool - FMU
	21. Combination options -
	22. Optional accessories & parts
Page 15	23. Drop Saw Unit - DSU
Page 16	24. Tongue Splitter Unit - TSU
Pages 17 -20	25 Photographs: A, 1 – 15/ B, 16 – 30/ C, 31 – 45/ D, 46 – 60
Page 21	26. Sharpening Guide & Contact Details



2. PARTS CHECK LIST

SCIONON® Graft Crafter™

Full Modular Unit/ Model FMU, Product Code SGC4

Check the contents against the parts inventory list as supplied.

Parts and fixings

1 x guillotine base block, with handle mounting system, & fitted fixings (5).

1 x glass reinforced guillotine handle with fitted blade.

1 x 4-way guide block (general use) - yellow.

1 x 4-way guide block (kiwi cleft) - green.

2 x tongue splitter block with fitted blade and blade cover.

2 x link guide block.

1 x reversible glass reinforced guide yoke.

1 x drop saw block with saw platform & slider block fitted.

Additional Hardware Fixings & Miscellaneous Parts

1 x Allen key set containing 3mm, 4mm, 5mm, and 6mm keys.

8 x M4 x 50mm self tapping hex head screws (for fixing GBU & TSU assemblies to work surfaces).

4 x M8 x 40mm button head screws (for fixing DSU assemblies to saw base).

6 x M8 x 20mm flat head screws (for securing assembly combinations together).

1 x depth stop adjustment knob (for DSU use with drop saws without built-in depth stop).

2 x spare guillotine blades with spare mounting screws (M3 x 8mm) & 2mm Allen Key.

1 x 30ml bottle of sap removal cleaning solution.

1 x 30ml bottle of multi-purpose lubricating oil.

1 x diameter measuring calliper, 5mm - 25mm scale.

Assembly/operator's manual - downloadable updates.

SCIONON® Graft Crafter™

PARTS EXPLODE VIEW

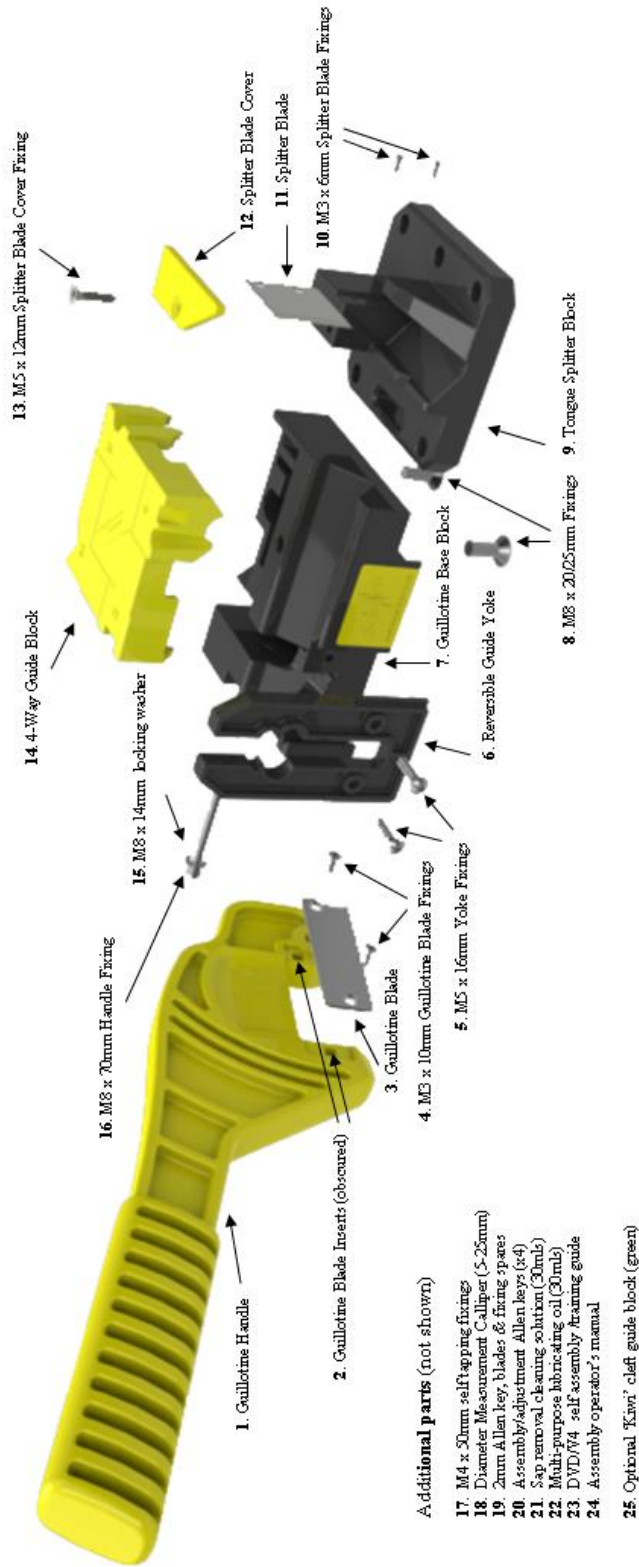

3. FULL PARTS EXPLODE VIEW – Model GBU3

Guillotine Base Unit - (GBU3)

January 2011

Product Code SGC6

Due to continued development parts may be subject to change without notice. Where possible new, additional, optional or changed parts will be compatible with earlier build versions.

4A. PARTS LIST - Guillotine Base Unit (GBU3)

Part #	Code	Description
001	GH3	Guillotine handle (with fitted thread inserts)
002	M3TI	M3 thread inserts
003	GHB6	Guillotine handle blade
004	M3x8FHSS	M3 x 8mm flat head socket screw (guillotine blade mount)
005	M5x16BHSS	M5 x16mm button head socket screw
006	GY3	Reversible glass reinforced guide yoke
007	GBB3	Guillotine base block with badge insert
008	M8x25FHSS	M8 x 20mm flat head socket screw
009	TSB3	Tongue splitter block
010	M3x6FHSS	M3 x 6mm flat head socket screw (splitter blade mount)
011	SUB3	Splitter unit blade
012	SBC3	Splitter blade cover
013	M5x12FHSS	M5x12 flat head socket screw (cover mount)
014	4WGB3	4-way guide block - (general use) yellow
015	LW8x14	Lock washer - M8 ID x M14 OD
016	M8x70x25SHCS	M8 x 70 x 25mm thread - socket head cap screw
017	M4x50STHHS	M4 x 50mm self tapping hex headed screw (surface mount)
018	DMC5-25	Diameter measurement calliper
019	AK2BF	2mm Allen key, blades & fixings
020	AK3-6	3mm, 4mm, 5mm, 6mm Allen key set
021	SRCS30	Sap removal/cleaning solution - 30mls
022	MLO30	Multi-purpose lubricating oil - 30mls
023	DVD4	DVD – self assembly/training guide - (view from website)
024	AOM3	Assembly operator’s manual - (now .pdf downloadable)
025	4WGB4	4-way guide block - (Kiwi cleft) green

4B. PARTS LIST - Drop Saw Unit (DSU)

Part #	Code	Description
008	M8x20FHSS	M8 x 20mm flat head socket screw
009	TSB3	Tongue splitter block
010	M3x6FHSS	M3 x 6mm flat head socket screw (splitter blade mount)
011	SUB3	Splitter unit blade
012	SBC3	Splitter blade cover
013	M5x12FHSS	M5x12 flat head socket screw (cover mount)
017	M8x40SBHSS	M8 x 40mm button head socket screw (drop saw mount)
019	AK2BF	2mm Allen key, blades & fixings
021	SRCS30	Sap removal/cleaning solution - 30mls
022	MLO30	Multi-purpose lubricating oil - 30mls
023	DVD4	DVD – self assembly/training guide - (view from website)
024	AOM3	Assembly operator’s manual - (now .pdf downloadable)
026	DSB	Drop Saw Block
027	DSP	Drop Saw Platform
028	DSS	Drop Saw Slider
029	LGB	Link guide block
030	M5x25SHCS	M5 x 25mm thread - socket head cap screw
031	M6x40HHB	M6 x 40mm hex head bolt
032	STKM624OD	Slider tensioning knob M6 x 24OD (black)
033	TKA	Tensioning knob assembly (knob, nuts, bolt & spring)

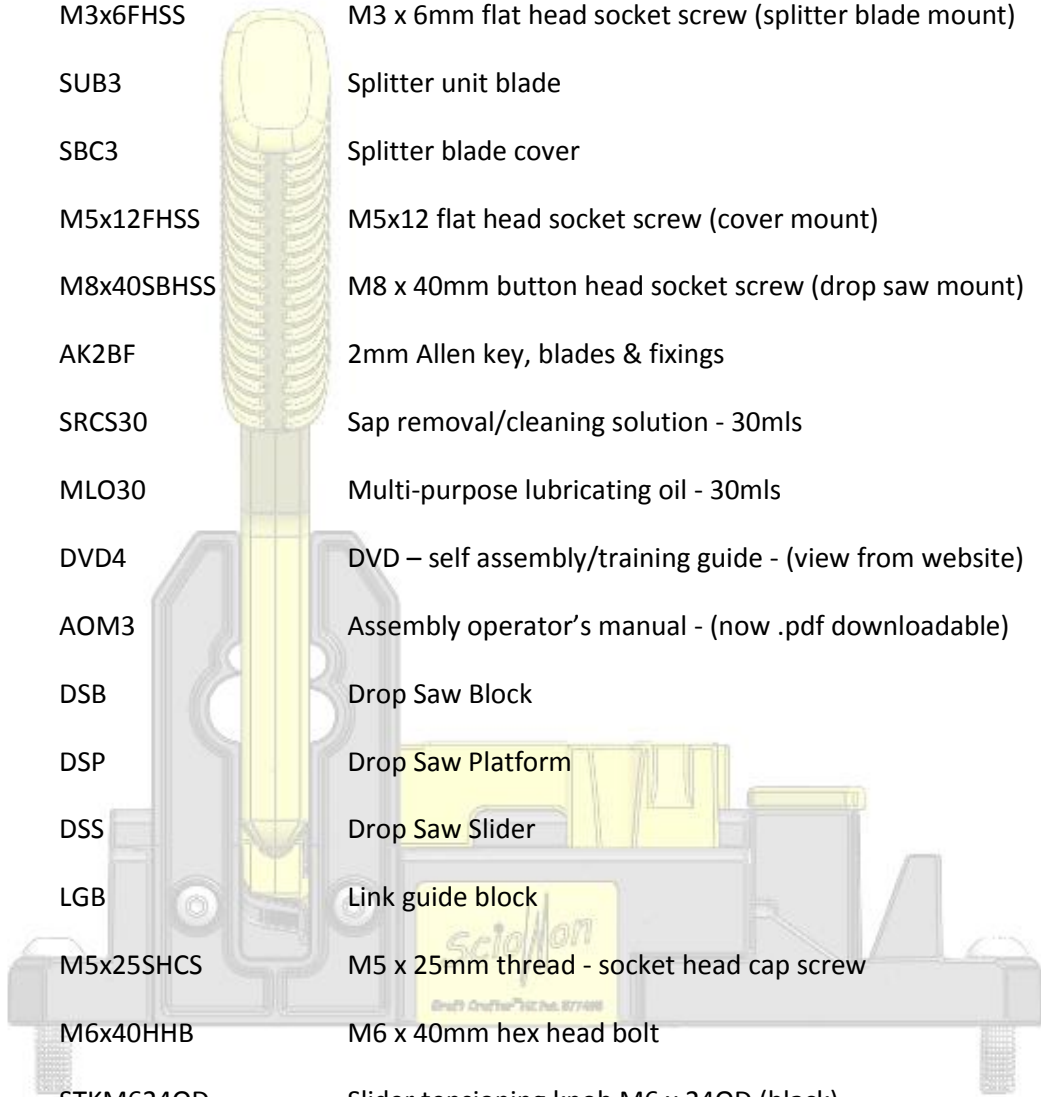

4C. PARTS LIST - Tongue Splitter Unit (TSU)

Parts 009, 010, 011, 012 & 013 combine to assemble the Tongue Splitter Unit

NB: Parts list 4A, 4B & 4C combine to assemble the Full Modular Unit - (FMU) assembly which also includes duplicate TSU & LGB footprint mountings.

5. FOUR STEP ASSEMBLY INSTRUCTIONS

Explode view showing full parts assembly of Graft Crafter – Guillotine Base Unit (GBU3).



Unpack your Graft Crafter and check the contents against the parts inventory provided.

Your Graft Crafter comes partially assembled. To complete assembly follow the steps below.



Step 1.

Fix the reversible guide yoke in position by sliding it into the recess channels. Secure in place with the M5 x 16mm button head socket screws using the 3mm Allen key provided.

Do not over tension.



Step 2.

Place a few drops of lube oil on the handle bosses. Fix the guillotine handle in place by slipping it into the recess channel. Secure in place with the M8 x 70mm cap screw using the 6mm Allen key provided. Place the locking washer on the outside. Tighten so that the handle is firm, then back off slightly.

Do not over tension.



Step 3.

Join the smaller splitter block to the guillotine base block by sliding it onto the recess tongue. Fix in place with the M8 x 20/25mm flat head socket screws using the 5mm Allen key provided. Tighten so that the two parts are secure.

Do not over tension.



Step 4.

Fit the 4-way guide block onto the guillotine base by pushing it firmly into the recess pockets. To adjust the guide profile to the desired position lift it off and rotate it by 90° intervals. Use the base blocks as a template and fix to your work surface with the M4 x 50mm self tapping screws (not shown) using a 10mm socket wrench.

Your SCIONON Graft Crafter is now ready for use. Make any necessary adjustments to the set-up as required, depending on the scion wood diameter you are working with. With practice and experience you will soon become familiar with the best set-up suited to your needs.

NB: Refer to pages 14 - 16 for Graft Crafter DSU & FMU assembly options and guidance on use. Refer to pages 17 - 20 for photographic examples of set-ups and use applications.

6. INTRODUCTION

Congratulations on the acquisition of your new SCIONON® Graft Crafter™. With care and practice you should get years of productive trouble free operation from your investment. The SCIONON® Graft Crafter™ is a revolutionary new tool which will efficiently aid scion preparation and assembly. It is a bench mountable device which enables increased safety & productivity for novices through to experienced propagators. With it you have the ability to accurately bench graft the technically difficult 'whip & tongue' graft with ease, or pre-prepare scions of many other different graft types for grafting on later in the field. For convenience the device is portable and can even be used in the field close to where you are working. It has been more than five years in development and is thoroughly field tested. The SCIONON® Graft Crafter™ will deliver and change the way you graft.

7. GETTING STARTED

First take 15 minutes or so to review this instruction manual and view the videos from our website. After viewing the video self assembly/training guide, assemble your Scionon® Graft Crafter™ Guillotine Base Unit (GBU) using the fixings & Allen keys supplied as per instructions below. Due to ongoing development this manual and videos will be periodically updated on the website.

8. ASSEMBLY DETAIL

1. Attach the reversible glass reinforced guide yoke to the main base block (**Fig. 2**). Position according to the wood diameter you will be working with. For medium size wood, (7mm - 12mm), position the yoke with the two intermediate holes to the right. For small wood, (5mm - 6mm) or large wood, (13mm - 15mm), reverse the yoke position. Fix in place using the two M5 x 16mm button head socket screws supplied using the 3mm Allen key. Tighten, but do not over tension.
2. For your convenience the handle comes with its cutting blade pre fitted. The blade is removable for cleaning, sharpening or replacement. Attach the guillotine handle using the M8 x 70mm assembly mounting system (**Fig. 3**). The locking washer goes on the outside as in the pre assembly. Use the 6mm Allen key to adjust the handle bolt to firm up, and then back off slightly to relieve the tension. The handle should feel firm but not be so tight that there is resistance when operating, nor feel so loose that it will fall of its own accord. Periodically adjust tension as necessary.
3. Attach the smaller tongue splitter unit (TSU) to the right hand side of main base block with the splitter blade facing to the front (**Fig. 4**). Fix in place using the M8 x 20mm &/or M8 x 25mm flat head socket screws supplied using the 5mm Allen key. Tighten, but do not over tension. The splitter blade can be removed when not required for tongue or split cuts.
4. Place the 4-way guide block (**Fig. 5**) onto the main body of the tool in the desired position by locating it in the cut-out pockets using the central pin. This guide block rotates 360° at 90° intervals. When changing positions lift the guide block off and rotate it to the desired position. Push down again to firm in place. Decide on your mounting place. Using the base blocks as a template, mark & drill 3 to five pilot holes using a 3/16 in. or 4mm drill bit. Fix in place using the M4 x 50mm self tapping hex head screws using a 10mm socket or wrench (not supplied).

Your SCIONON® Graft Crafter™ Guillotine Base Unit is now ready for operation.

9. SAFETY FIRST

- Take care when handling the blades that you do not accidentally cut yourself.
- Never place any part of your hand in the device in such a way that you may cause personal injury.
- Always be aware of your actions when operating, so as not to cause injury to yourself or others.
- Keep your work surface clear of clutter and remove debris often.
- With commonsense and good practice you will have safe, effortless, trouble free operation of your SCIONON® Graft Crafter™.

10. PREPARATION

Your SCIONON® Graft Crafter™ (SGC) - Guillotine Base Unit (GBU) is capable of preparing a wide range of scion wood types of between 5mm & 15mm in diameter. If you have need to prepare scion wood of greater diameter than 15mm, the SCIONON® Drop Saw Unit (DSU) is available which when teamed up with a basic drop saw will allow you to prepare wood of between 10mm to 25mm. Do not over stress your tool by attempting to cut extremely hard dry woods or diameters that exceed recommendations, as damage to blades and or fixings may result.

With practice and patience you will quickly become familiar with the SGC's operation and master all the grafting techniques you require with ease. Before you begin working with your SCIONON® Graft Crafter™ you are advised to review the operators manual &/or view the self training DVD included in the kit. When you are satisfied that you are ready to begin work make sure your work surface is rigid & stable and clear of clutter. Have at hand water, secateurs, grafting knife, suitable binding tape & wound dressing paint or wax. It is advisable to make practice cuts on waste wood to familiarise yourself with the basic operation before you commence work in earnest.

Remove sufficient wood from storage for your daily requirements. Dry wood should be re-hydrated for a period of 12 to 48 hours prior to use depending on need. Most woods if stored correctly will not need anything other than being brought up to ambient temperature prior to use.

11. PRACTICE CUTS

Select your scion wood and remove the tips and ends ensuring you select the best wood available to work with. At this point discard any suspect wood also, but retain it. Use this to practice on while getting familiar with how to use your SGC. Roughly section the wood into thirds. Typically you will end up with lengths ranging from 5mm to 8mm, 9mm to 12mm, & 13mm and larger in diameter.

To familiarise yourself with the functions and operation of your SGC, start by making practice cuts using the previously removed waste wood. Adjust the 4-way guide block (**photo 17**) to familiarise yourself with the subtleties of its function. Try cutting whips (**photos 2 & 3**) at first to get the feel of the slicing action & experiment using differing wood diameters to get the feel of how to create the whip length you require. Do this by holding the scion wood at various different angles (either forward or to the right) against the guide block.

When you are satisfied that you have mastered cutting the whip and are able to prepare rind grafts (**photo 3**) with ease, move on to practicing the tongue cut to create a whip & tongue graft (**photo 6**). With patience and practice you will also soon feel at ease with this function and be able to create uniform matching scions that lock together with a secure snug fit. Careful placement of the scion wood against the guide block & blade will ensure the consistency you have not achieved previously.

When satisfied move on to creating the other graft types available to you by experimenting further. The 'V' cleft (**photo 12**) & wedge (**photo 9**) grafts may take a bit more practice to perfect but your perseverance will pay off in the long run. Practice also being more precise when placing scion wood into the guide to get the feel of how to cut uniform chips (**photo 13**) for chip buds (**photo 15**). It is always a good practice not to rush the alignment of the scion wood against the guide block or the blade. With time, when combined with a natural rhythm, speed and accuracy will increase.

12. CUTTING & SHAPING THE SCIONS

Select the wood you will be working with and decide on the manner in which you will cut to length. To cut scions of up to 12mm in diameter the graft wood can be further sectioned into the desired scion length using the guillotine function (**photo 25**) or secateurs. Alternatively the wood can be individually sectioned each time the face whip and/or the tongue cut is made (**photo 26**) – useful if one bud grafts are to be prepared when wood is precious.

Decide on the appropriate graft type depending on your scion wood & understock match. In addition to 'whip & tongue' grafts (**photo 6**), you are able to prepare chip buds (**photo 15**), rind (**photo 3**), 'V' cleft (**photo 12**) & wedge grafts (**photo 9**) with the SCIONON® Graft crafter™. The Whip & tongue & 'V' cleft can be completed with the Graft Crafter™ when bench grafting is desired (**photos 23 & 24**). The chip bud can also be completed at the bench but will require the use of a grafting knife to 'T' or notch cut them onto the rootstock. Alternately, they along with the rind & wedge grafts can be held in water & later placed onto the understock in the field using a grafting knife. Cut scions can be held in buckets of water for several days until utilised. If kept for periods of longer than one day the water should be changed daily or depending on the wood type, they can be held in distilled water and stored under refrigeration for up to a week. This is useful when working through periods of wet weather.

Place the 4-way guide block (**photos 16 & 17**) with the preset guide angle to the desired position, depending on the wood diameter range you are working with. The guide block is set with pre-determined angles which accept wood ranging from 5mm to 15mm in diameter, allowing uniformity of cut and ensuring the desired length & slope of the whip produced. The operator can also control the bluntness of the tip end of the scion which will determine the amount of overhang when matching whip & tongue grafts (**photo 6**) onto rootstock or preparing rind grafts (**photo 3**) for later placing onto understock in the field.

NB: Extremely dry woods or medium density woods 13mm & greater in diameter should only be sectioned using secateurs, as resistance may cause damage to the cutting blade and other fixings due to a crushing action being encountered & the tool being overstressed.

13. PREPARING RIND GRAFTS

The first cut for all grafts is the whip cut (**photo 2**). With the guillotine blade handle vertically upright & to the rear, position the scion wood in the appropriate guide block recess with buds facing upwards and any bottom bud facing to the left. While holding the wood with the right hand, draw the guillotine handle down towards the front with the left arm. The blade will slice into the scion wood and finish the cut while being guided through the guillotine yoke (**photo 7**). This results in a precise straight cut being made ranging in length depending on operator placement and the graft wood diameter.

The operator has some user control of the acuteness of the whip produced by the positioning of the wood when held in the guide block. Small diameters are held forward in the guide block recess which will create the longest possible whip, while if a shorter whip is required the scion wood can be held as far back and to the right as the recess will allow. With care and practice the operator will quickly master this simple action with effortless ease, resulting in consistent uniformity of the scions produced.

Three preset guide positions will give even more precise uniformity, these being 8mm, 12mm & 16mm. As scion wood diameter changes you simply alter the guide face to be used to match the appropriate diameter range being cut. With practice & care experienced operators will be able to use the 16mm guide face (**photo 7**) for most scion wood diameters, without the need to alter the guide block profile as often.

This guillotine slicing action produces rind grafts (**photo 3**) and/or waste chips (**photo 13**) which can be held in water, wrapped in damp cloth or sealed in plastic for later placement onto understock in the field.

14. PREPARING 'WHIP & TONGUE' GRAFTS

To prepare whip & tongue grafts (**photo 6**) a second tongue cut is made to the scion wood by changing hands and placing the previously cut whip horizontally through the guide yoke (**photo 4**) and pushing to the right while guiding it into the appropriate semi-circular hole. While holding the wood with the left hand and the guillotine handle in the right, the whip is carefully placed against the blade (**photo 5**) using the top of the pith as a guide. In most cases this will mean the blade is resting against the scion wood between 1/4 & 1/3 of the way along the previously made sloping cut. This is the best place to start the incision to create the tongue cut to allow uniform matching of the whip & tongue unions and prevent overhang which will require additional tail trimming. With practice you will get good at precisely judging the depth of tongue cut required and similar wood & stock diameters will match correctly producing tight well anchored, strong graft unions (**photo 31**).

When sufficient scions have been produced they can be held in water while the rootstocks are prepared following similar steps. The rootstock is cut to the desired length and placed in the guide block recess with the roots (if any) at the top. The same placement and action is followed as for preparing the scion wood. With pre grading, similar diameters will ensure scions and rootstocks match correctly and firm cambium contact is guaranteed on at least one, if not both sides.

When ready the graft union is made by firmly pushing the scion and rootstock together while taking care to align the cambium layer. If excessively wet allow the union to dry slightly. Then the union is bound together with suitable grafting tape and the tip of the scion waxed or painted with a suitable sealant. If desired plant out immediately or pack in appropriate medium and store until ready to plant.

With the correct placement, alignment and care sealing them (and provided you have a firm fit), your graft unions will take minor handling knocks without becoming dislodged or compromised ensuring high success of take.

15. PREPARING WEDGE GRAFTS

The 16mm guide profile is also utilised to cut the wedge graft. The first cut is made as described above (typically prepare several hundred at a time & hold in water until ready to finish into wedge or 'V' clefts), then a second cut is made by placing the cut surface of the whip on the forward flat surface of the guide block (**photo 8**). While holding with the right hand, draw the guillotine handle down through the scion wood with the left arm slicing the wood to form a wedge shape. With practice the positioning of the scion wood will result in a symmetrical wedge being produced (**photo 9**). A second cut can be made if the wedge formed is not precise on the first attempt. Store in water or wrap in a damp cloth until ready to graft on in the field with a suitable grafting knife, chisel or saw etc.

16. PREPARING 'V' CLEFT GRAFTS

When a 'V' cleft graft (**photo 12**) is required cut a rind graft as previously described. When diameters exceed the 8mm profile use the flat face of the 4-way guide block to finish the cleft graft. Smaller diameters (5mm - 10mm) can be shaped using the 8mm guide profile without the need to rotate the guide block (**photo 11**). Place the previously cut rind graft against the face of either of the flat sloping surfaces, depending on the scion diameter (**photos 10 & 11**). Draw the guillotine handle down as previously described. In normal situations the second cut will produce a matching slope resulting in a 'V' being formed. This may take several attempts to perfect, but with patience & experience you will be able to adjust the height and slant of the wood to the correct angle to produce these grafts with ease. If the 'V' is not uniform a second cut can be made to centralise the 'V' of the cleft scion. These grafts can be stored in water until ready to either graft on to understock in the field or complete at the bench.

To prepare the root stock to receive the 'V' cleft graft, cut the rootstock to the desired length below a bud. Now place the rootstock into the guide yoke and align the end so that the blade is resting in the middle on the top of the rootstock. With the left hand tension the rootstock against the appropriate semi-circle to the right. Now draw the guillotine blade through the top of the rootstock with the right hand until a split results (**photo 23**). With practice you will create the desired split to accept your previously prepared 'V' grafts. Carefully push firmly together (**photo 24**) taking care to align the cambium layers on at least one side, seal and store for use as described above. It is sometimes useful to use scion wood slightly larger in diameter than the rootstock. This will often result in cambium contact matching on both sides of the graft union.

17. PREPARING CHIP BUDS

To cut chip buds (**photo 15**) more exacting care is required when placing the scion wood into the guide block. Position the guide block to accept the graft wood diameter you are working with. Place it in the guide in such a way so that a chip can be removed with a bud retained centrally on the chip (**photos 2 & 13**). The chip thickness and size is determined by the guide profile used depending on the graft wood diameter. Taper the end below the bud using a grafting knife or secateurs (**photo 14**) and retain in water until 'T' budded or notch cut into the receiving stock or budded on out in the field.

NB: When preparing all the previously described grafts, if the correct care is taken each time the whip cut is made, chip buds can be retained for later use if desired. This is extremely useful if wood is scarce and precious.

18. BLADE CARE & REPLACEMENT

The blade is the backbone of your SGC. Depending on use, wood type, hardness and diameters prepared, it should produce many thousands of cuts without requiring sharpening or replacement. It will however be necessary to regularly remove the handle from the base block to inspect, clean and sharpen the blade. It is not necessary to always remove the blade from the handle when cleaning or a light 'touch-up' sharpening is required. This can be done with a small carbide or fine diamond file, or wet stone by lightly stroking the bevel tip and finishing with a leather strop or wet/dry sandpaper. Remove sap build-up with a suitable sap removal product when sap residue begins to contaminate the cuts. Clean with rubbing alcohol or similar at least daily depending on use and need.

Regularly inspect the blade. Periodically remove it from the handle to fully clean, hone, sharpen or replace it using the 2mm Allen key supplied. Do this as often as necessary, when you feel that the blade has more resistance when cutting through the wood or cuts become ragged or grainy. Use a tooth brush or similar to help keep the blade clean. See additional sharpening tips (page 21).

Do not attempt to sharpen the blade yourself unless you are familiar with double bevel blade sharpening procedures. If unable to do so yourself, it is advisable to have the blade professionally sharpened to maintain the correct 13° - 15° bevel tip necessary for effective use.

Replacement blades are readily available in packs of 2, 5 and 10.

19. GENERAL MAINTENANCE & STORAGE

Periodically inspect your SGC for damage or excessive wear. If parts are damaged or worn excessively replacement parts can be ordered, or you can return the complete tool to your supplier for inspection and service.

Prior to prolonged storage completely strip the tool down and clean with warm soapy water using a soft cloth or soft bristled nylon brush. Use a disinfectant wash to rinse all parts and allow to air dry completely before storage. To protect the cutting blades rub with oil when storing and place in the storage pocket on the main guillotine base.

20. MODULAR MULTI-TOOL - FMU

Your SGC is modular and can be added to if your requirements change. The Drop Saw Unit (DSU) can be used independently or will clip onto the existing GBU by removing the Tongue Splitter Unit (TSU). The device's modular functionality allows for multiple station use allowing real versatility when required. Two GBU's can also be clipped together (2nd GBB optional) if desired and can be centrally mounted to your work surface for two person operation at a very cost effective price. One person can prepare scions while the other prepares the rootstock. Other persons can then assemble tape, paint and pack the completed grafts for storage or planting out directly. Alternatively, additional multiple individual Graft Crafter parts can be purchased separately and installed as desired.

21. COMBINATION MODULE OPTIONS

SGC1 - GBU1: Guillotine Base Unit - original Graft Crafter™ tool supplied with LGB

SGC2 - DSU1: Drop Saw Unit - DSU supplied with 1 x LGB & 1 x TSU

SGC3 - TSU1: Tongue Splitter Unit - assembled tongue splitter block

SGC4 - FMU1: Full Modular Unit - complete with GBU, DSU, 2 x TSU, 2 x LGB & 2 guide blocks

SGC5 - DSU2: Drop Saw Unit - DSU supplied with 2 x LGB

SGC6 - GBU3: Guillotine Base Unit - standard Graft Crafter™ supplied with TSU & std guide block

SGC7 - GBU2: Guillotine Base Unit - GBU supplied with 1 x TSU, 1 x LGB & 2 x guide blocks

22. OPTIONAL ACCESSORIES & PARTS

Spare guillotine blades - 2, 5 or 10 packs

Guide block accessories - 4WGB1, 4WGB2, 4WGB3, 4WGB4, 4WGB5

LGB - Link guide block

TSB - Tongue splitter block, blade, cover & fixings

All replacement parts (see separate list - page 5)

Other SCIONON® Products

SCIONON® Straight bladed safety knife™ - (for left or right handed users)

SCIONON® Grafting Shears™ - (Three models: SGS1-13, SGH2-16, SGK3-19)

SCIONON® Carry pouch/ storage holster - (combination pouch for Grafting Shears & knives)

23. USING THE DROP SAW UNIT

The Drop Saw Unit (DSU) is designed as an accessory to the GBU or for use on its own as a stand alone tool (**photo 32**). It can be assembled in a variety of ways and mounts to the base of a standard 210mm -250mm drop saw for use (**photo 33**). For best results SCIONON® Graft Grafters™ tools are recommend to be used with a good quality tungsten carbide tipped blade with at least 40 teeth when used in the drop saw application. When teamed up with the GBU the SCIONON® Graft Crafter™ is referred to as a **Full Modular Unit (FMU)**. When operated as the complete Graft Grafters™ Full Modular Unit (**photo 37**) the full assembly is made by fitting all the components together and securing from underneath with the M8 x 20/25mm flat head socket screws (**photo 34**).

Make sure that you have adjusted the saw and trued it to cut straight before marking your mounting points - (**photo 35**).The FMU is placed onto the base plate of a drop saw taking care to centre the saw blade by aligning it in the Link Guide Block (**photo 36**). The body of the tool is used as a template and positions for fixings are marked to mount the unit firmly onto the saw base (**photo 37**). Three or four holes are drilled using a 6.5mm - 7mm drill bit and tapped to take the M8 x 1.25mm button head socket screws to fix in place. If you do not have an M8 x 1.25mm tap, the holes can be enlarged and standard M8 x 1.25mm nuts & spring washers used to firm in place. If the GBU is not attached to the DSU, additional mounting holes are drilled to secure the left side of the Link Guide Block (LGB) to the saw platform base (**photo 38**).

Lower the saw blade to rest on the Link Guide Block (**photo 39**). If your saw has a depth stop adjust this to allow the saw to cut into the LGB about 2 -3 mm. This ensures that the graft wood will be severed completely when cutting it. It should not be necessary to cut into the LGB any further than to the bottom of the 'V' valley. This should be the deepest point where the saw depth adjustment is set to cut to. Larger 250mm saws will create a deeper and longer incision. Take care to cut in only as deeply as is necessary to completely sever the graft wood when it is resting in the guide. If the saw you are using does not have a depth stop use the depth stop adjustment knob supplied (**photo 40**). This doubles as the slide block locking mechanism also. Both adjustments can be made independently. The threaded rod can be cut if necessary for the adjustment to suit your saw.

The DSU is best used to cut scion wood of between 10mm to 25mm in diameter to create whip and tongue grafts. To do this the graft wood is sectioned into lengths using the saw or secateurs. The slide block is positioned to allow the largest diameter end of the graft wood to fit into the slide block opening while resting against the rear stop and guide on the left (**photo 41**). Alternatively, curved woods can be allowed to slide up over the stop to align correctly (**photo 42**) - useful also if buds on the graft wood are large or fragile, or bud node spacing will not allow them to sit on the saw block.

In addition to 'whip & tongue' grafts (**photo 31**), you are able to prepare rind (**photo 3**) & 'V' cleft with the DSU. This is done by turning the wood and making a second cut (**photo 43**). Decide on the appropriate graft type depending on your scion wood & understock match. The whip & tongue & 'V' cleft can be completed with the TSU when bench grafting is desired (**photos 44 & 45**). Cut rind & cleft grafts can be held in buckets of water for several days until grafted on in the field. If kept for periods of longer than one day the water should be changed daily or depending on the wood type (malus), they can be held in distilled water and stored under refrigeration for up to a week. This is useful when working through periods of unsettled weather.

NB: Damage to the Link Guide Block (LGB) will occur due to normal use. It is considered a consumable part and is readily available as a replacement part. It is not recommended to cut graft woods of less than 10mm in diameter when using the Drop Saw Unit to prepare grafts.

If this is attempted the smaller diameters could jam between the saw blade and guide resulting in premature damage to the LGB and or other fixings due to saw blade deviation being encountered.

24. USING THE TONGUE SPLITTER UNIT – (TSU)

The Tongue Splitter Unit is interchangeable with the GBU (**photo 1**) and the DSU (**photo 32**). The standard GBU is now supplied with the TSU as a standard footprint mount. This increases the GBU's versatility. The DSU is supplied with two mounting blocks - one Link Guide Block (LGB) and one TSU. The TSU can also be purchased separately for independent use. Both the TSU and LGB have the same footprint (**photo 34**) ensuring the same mounting holes can be used when interchanged between assemblies. Spare Link Guide Blocks can also be supplied separately.

When attached to either the GBU or DSU, or separately mounted to a work surface, the TSU can be used to make tongue cuts (**photo 44**) into scion wood and stock material for whip and tongue grafting or used to cut splits (**photo 45**) into stock material to receive cleft grafts (**photo 43**). The pre sized stock material is simply centrally aligned on the splitter blade and tapped against the blade to create the desired split cut. Different diameters are accommodated by the guide slope on the right hand side of the splitter unit which also assists in aligning the wood when making a tongue cut.

Small diameters can just be tapped with the fleshy palm of your hand above the thumb. Use a glove to cushion your inner palm if necessary. Larger diameters are best finished by tapping with a rubber or soft wooden mallet or similar. When correct placement is achieved your scions will match perfectly with your under stock resulting in neat secure graft unions (**photo 31**).

Visit our website www.scionon.com periodically for updates on new products and accessories.

We welcome your feedback of your experiences using SCIONON® products.

SCIONON® - Developers of Innovative Grafting Tools

25A. Photographs 1 - 15: Showing basic graft cuts produced



25B. Photographs 16 - 30: Showing additional functions



25C. Photographs 31 - 45: Drop Saw Unit - (DSU) set-ups



25D. Photographs 46 - 60: Showing Drop Saw Unit functions

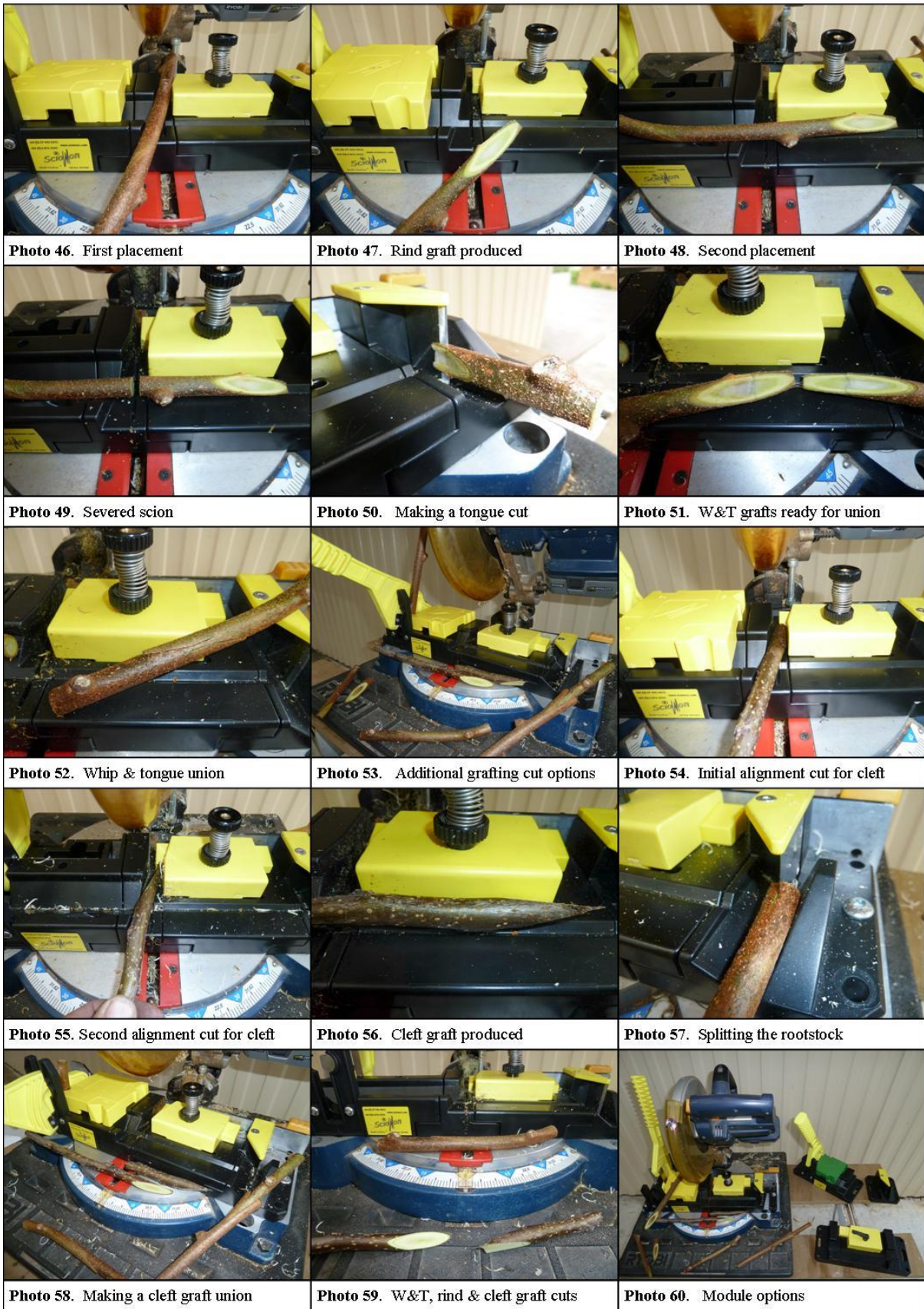

26. BLADE SHARPENING & MAINTENANCE TIPS



1. Blades have 2mm of tip wear available. If damaged, rub the blade tip and sides on a flat wet sharpening stone.



2. Restore bevel by rubbing on the sharpening stone, stroking with a carbide file or...



3. ...a fine flat diamond file or small wet stone. Sharpen only the bevel side of the blade. The tip bevel should be no greater than 15°.



4. Polish the bevel & remove any remaining burr with 1200 grit wet/dry sandpaper. Rub the flat back of the blade once to finish.



5. Alternatively, use a powered wet grinding stone and finish on a burnishing wheel or leather strop.



6. Finished tip bevel should be about 1mm. When necessary hone the secondary bevel back to maintain the shape in the same way.

7. Periodically clean to remove sap residue build-up with a suitable sap removal product. Lightly oil when not in use and store spare blades in the pocket on tool base or pouch.

Ian Adams – Scionon Ltd, 712 Maxville Drive, Parkvale, Hastings 4122, Hawke's Bay, NZ

Phone: mobile +64 (0)27 443 5472, A/H +64 (0)6 876 8529

Website: www.scionon.com E-mail: ian@scionon.com